

Architectural TRCB™

Tight Radius Cylindrical Bending and Tempering System

Glasstech's TRCB system offers unprecedented freedom of design and creativity for architects and designers worldwide. The system bends and tempers glass quickly, easily and without tong marks, and forms complex glass shapes to exacting tolerances with the highest level of uniformity and excellent optical quality.

The TRCB system can process a wide range of shapes, including:

- Cylindrical curves
- Tight radius V shapes
- Combination bends of up to three flat sections and two tight radius bends
- A variety of other symmetrical and asymmetrical shapes

As a result, the system offers numerous options for creating attractive retail displays, showcases with minimal framing, distinctive shower enclosures, exciting furniture shapes and one-piece kiosk and booth panels. Additionally, all formed glass is tempered to meet applicable international fracture standards.

Equally important, creativity is not sacrificed for throughput. TRCB uses two interchangeable sets of rollers which are articulated by computer control to create a broad range of bends quickly and accurately, eliminating the need for expensive molds.

Best of all, the modular design of Glasstech's TRCB system permits total system flexibility and adaptability in any production setting.

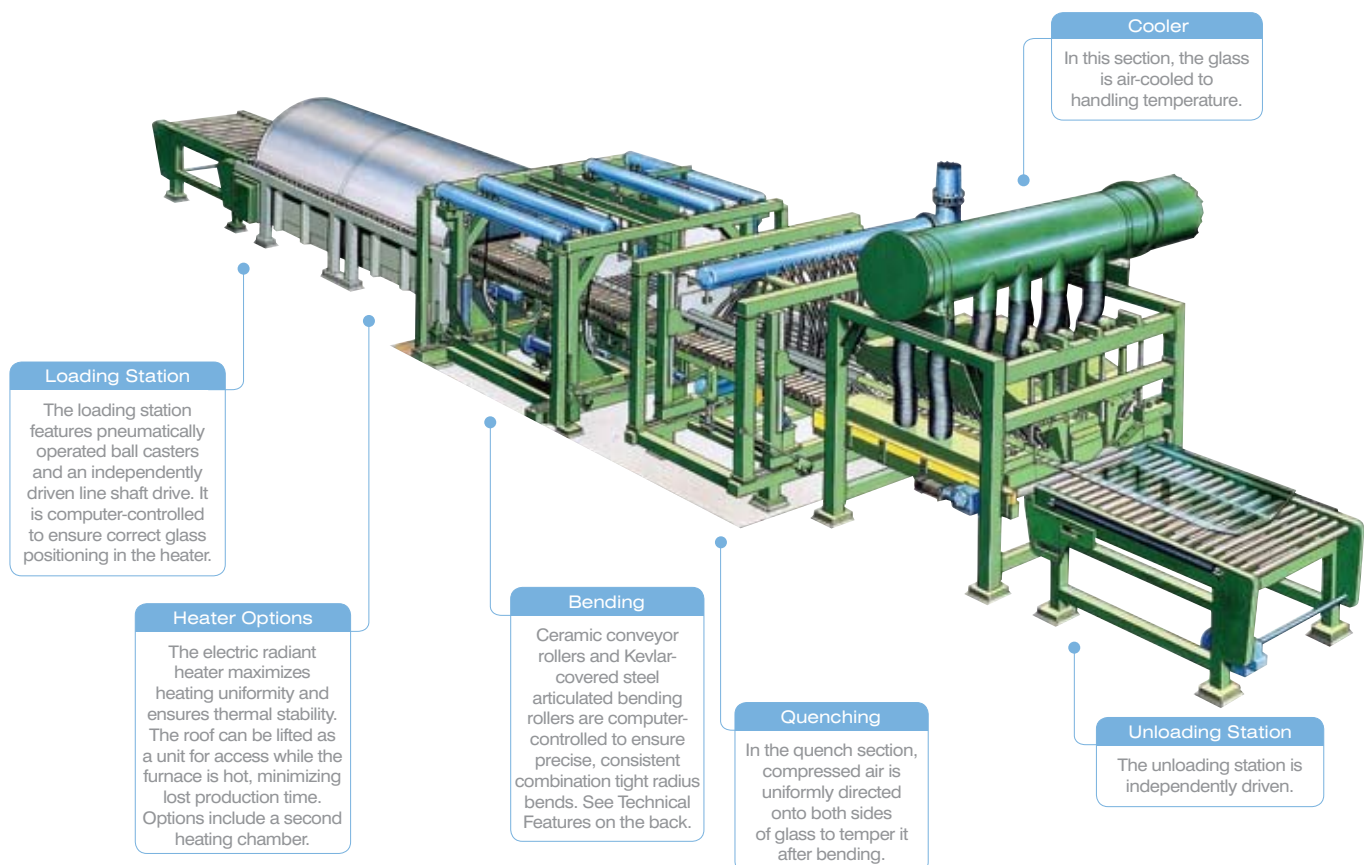

Architectural TRCB™ Technical Features

Production Capability – Loads/Hour

Glass Thickness		Maximum Production Rate Loads/Hour		Maximum Single Piece* Z97 & BS 6206		Maximum Piece* ECE R43 & JIS 3211	
(mm)	(in)	Single Chamber System 5.5m (18') Heater	Double Chamber System 11m (36') Heater	(mm)	(in)	(mm)	(in)
3.0	.118	26	52	1000 x 2000	40 x 79	-	-
3.2	1/8	26	52	1000 x 2000	40 x 79	-	-
4.0	5/32	22.5	45	1220 x 2440	48 x 96	815 x 1500	32 x 59
5.0	3/16	18	36	1220 x 2440	48 x 96	1220 x 2440	48 x 96
6.0	1/4	14	28	1220 x 2440	48 x 96	1220 x 2440	48 x 96
8.0	5/16	9	18	1220 x 2440	48 x 96	1220 x 2440	48 x 96

* Minimum glass size: 380mm (15") in the direction of travel.

In actual operation, continuous production rates will be between 50% and 75% of the available load area and will depend on glass dimensions, edgework quality and load area utilization. Production rates for ceramic frit-coated panels will vary depending on part size, thickness and the specific type of frit used, the frit pattern and the consistency of the frit thickness.

Installed Electric Power

Heater Length	Heating	Quenching**	Cooling	Drives	Total
	(kW)	(kW)	(kW)	(kW)	(kW)
Single Cycle – 5.5m (18')	800	260	75	22	1157
Double Cycle – 11m (36')	1200	540	115	22	1877

** Quench power based on ECE capability for 3.0mm (.118") thickness.

A. Combination Tight Radius Bends (Category I)

Bends with 2 or 3 flat sections with 1 or 2 tight bends with a minimum radius of 100mm (4").

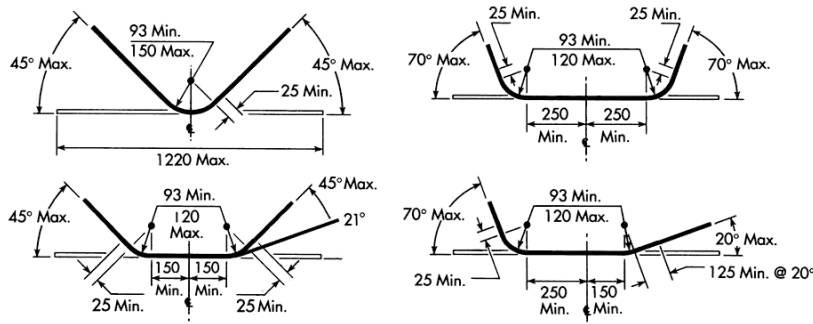

B. Cylindrical Bends (Category II)

Bends with radii from 254mm – 6000mm (10" – 20"). Shapes are set with templates.

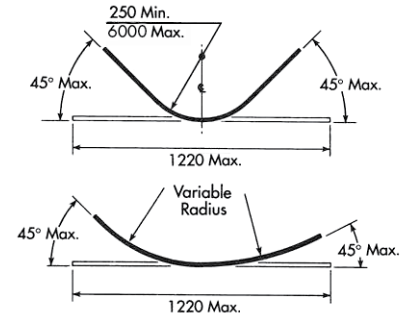

Glasstech, Inc.
Perrysburg, Ohio USA
Tel: +1-419-661-9500
Fax: +1-419-661-9616

Glasstech, Inc.
New York, New York USA
Tel: +1-212-489-8040
Fax: +1-212-307-5781

Glasstech, Inc.
Shanghai, China
Tel: +86-21-5836-7560
Fax: +86-21-5836-8968

glasstech®
WHERE INNOVATION CONTINUES
www.glasstech.com



Glasstech, Inc.
Mumbai, India
Tel/Fax: +91-22-6710-1629

Glasstech Limited
Worcester, England
Tel: +44-1905-723663
Fax: +44-1905-20400